

▼ Shown from left to right: ZE3304ME-K, ZE4110DE-FHR



- High-efficiency pump design – higher oil flow and by-pass pressure
- High-strength, moulded electrical box protects electronics, power supplies and LCD readout and stands up to harsh industrial environments
- IP54 protection and isolation class
- Back-lit LCD provides self test, diagnostic and read-out capabilities never before offered on an industrial pump (included on pump with electric valves, optional on other models)
- Totally enclosed, fan-cooled industrial electric motors for extended life
- User adjustable relief valve built-in on manual and solenoid valves. Oil ports on valves are 3/8" NPTF
- Steel fan guard on all electric motors
- Full sight oil level glass on 9,8, 19,8 and 39 litres reservoirs, oil level indicators on 4,6 and 6,8 litres reservoirs.
- 40 micron filter breather with splash guard
- Durable steel reservoirs.



◀ Rail wheel pulling using RACH aluminium cylinder powered by ZE-Series pump.

ZE Series

Reservoir Capacity:

4,6 - 39 litres

Flow at Rated Pressure:

0,55 - 2,73 l/min

Motor Size:

0,75 - 5,60 kW

Maximum Operating Pressure:

700 bar

Z Tough
Dependable
Innovative
CLASS



Speed Chart

To determine how a specific pump will operate your cylinder, see the Pump-Cylinder Speed Chart in the 'Yellow Pages'.

Page: 405



Locking Valves

For applications requiring positive load holding, VM-Series valves (except VM32) are available with a pilot-operated check valve

VM33L and VM43L. This provides hydraulic locking of the load until the valve is shifted into the retract position.



Assisted Return Pumps

To improve productivity and plunger retraction, Enerpac offers valve configurations designed to accelerate your cylinder retraction

speeds, ZU4 and ZE-Series pumps feature **Venturi Valve Technology** to facilitate the faster return of single-acting gravity and spring return cylinders. See valve type in ordering matrix and details in section Directional Control Valves.

Page: 122

ZE-Series, Specifications & Dimensions

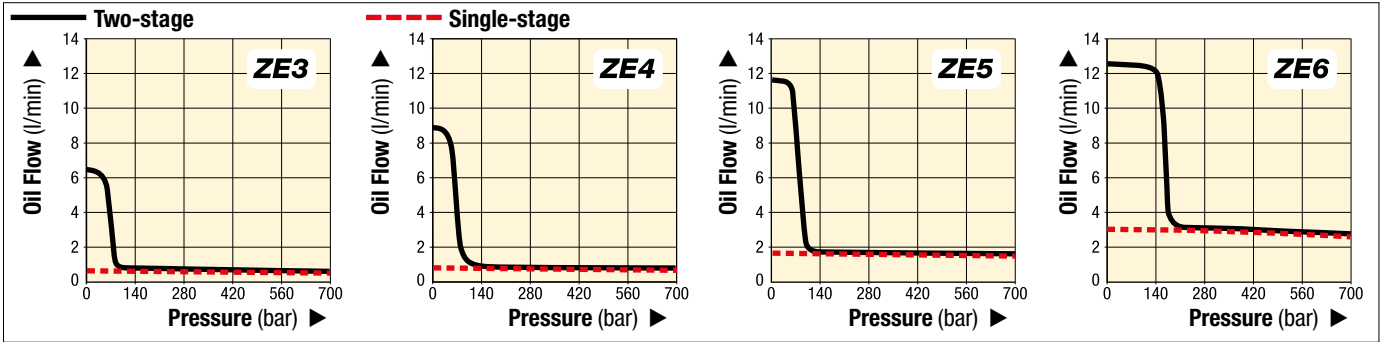

▼ ZE-SERIES PERFORMANCE CHART

Pump Series	Output Flow Rate at 50 Hz * (l/min)				Pump Unit	Available Reservoir Sizes (litres)	Motor Size (kW)	Relief Valve Adjustment Range (bar)	Sound Level (dBA)
	low pressure		high pressure						
	at 7 bar	at 50 bar	at 350 bar	at 700 bar					
ZE3	0,59	0,59	0,57	0,55	Single-stage	4,6 - 6,8 - 9,8	0,75	70-700	75
	6,15	5,26	0,57	0,55	Two-stage	19,8 - 39			
ZE4	0,87	0,87	0,84	0,82	Single-stage	4,6 - 6,8 - 9,8	1,12	70-700	75
	8,88	8,20	0,84	0,82	Two-stage	19,8 - 39			
ZE5	1,75	1,72	1,68	1,64	Single-stage	9,8 - 19,8 - 39	2,24	70-700	75
	11,61	11,27	1,68	1,64	Two-stage				
ZE6	3,00	2,94	2,86	2,73	Single-stage	9,8 - 19,8 - 39	5,60	70-700	80
	12,29	12,15	2,86	2,73	Two-stage				

* Oil flow will be approximately 6/5 of these values at 60 Hz.



Single or Two-Stage

Choose single-stage pumps for applications that require constant flow regardless of pressure such as testing or clamping. Two-stage pumps have an increased output flow at low pressure to allow fast movement towards the load, for reduced cycle times and increased productivity.

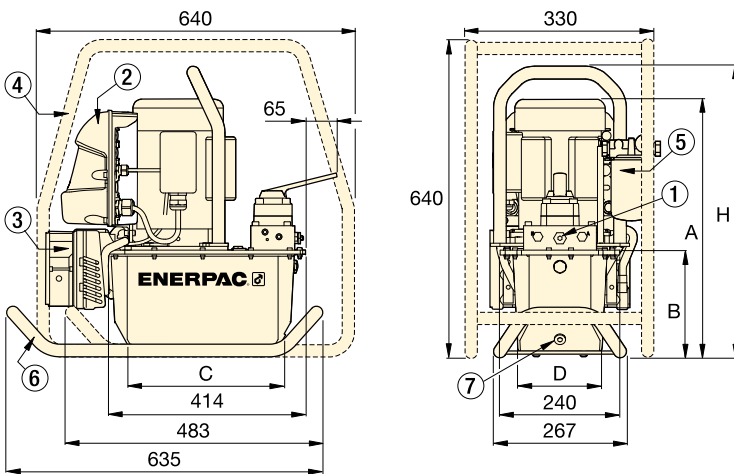

ZE-Series Pumps with 4,6 - 6,8 litres reservoir

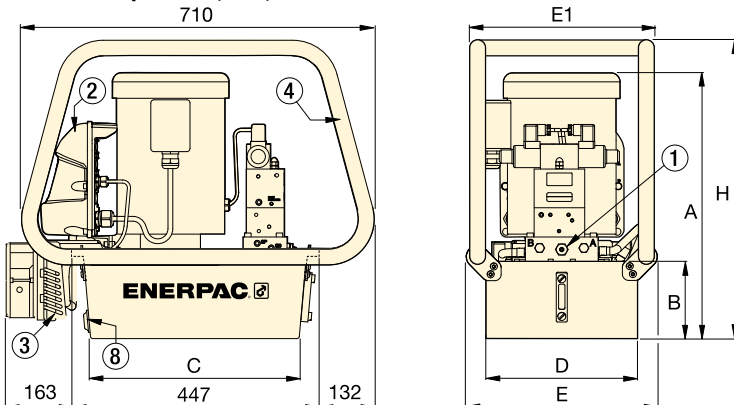

ZE-Series Pumps with 9,8 - 19,8 - 39 litres reservoir

- ① User adjustable relief valve on all manual and solenoid valves. $\frac{3}{8}$ " NPTF on A and B ports; $\frac{1}{4}$ " NPTF on auxiliary ports.
- ② Electric Box
- ③ Heat Exchanger
- ④ Roll Cage
- ⑤ Return Line Filter
- ⑥ Skid Bar
- ⑦ Magnetic Oil Drain
- ⑧ Oil Drain / Oil Level & Temperature Switch

Reservoir Size (litres)	ZE-Series Pump Dimensions (mm)						
	A	B	C	D	E	E1	H
4,6	457	143	279	152	-	-	513
6,8	457	143	279	206	-	-	513
9,8	533	158	419	305	384	371	600
19,8	558	180	419	422	501	488	625
39	648	270	399	505	576	572	715

▼ STEP 1: Select a pump from the Pump Ordering Matrix

The functionality of the pump can be determined by the model number. Utilize the guide below to select the best pump for the application from the pump ordering matrix.

Z	E	4	4	20	M	E	-	F	H
1	2	3	4	5	6	7		8	
Product Type	Motor Type	Flow Group	Valve Type	Reservoir Capacity	Valve Operation	Voltage		Factory Installed Accessories	

1 Product Type

Z = Pump Class

2 Prime Mover

E = Induction electric motor

3 Flow Group

3 = 0,55 l/min @ 700 bar

4 = 0,82 l/min @ 700 bar

5¹⁾ = 1,64 l/min @ 700 bar

6¹⁾ = 2,73 l/min @ 700 bar

4 Valve Type

0 = No valve, with cover plate

1 = 3/2 Dump valve **VE32D**

2 = 3/2 manual **VM32**

3 = 3/3 manual **VM33** or electric **VE33**

4 = 4/3 manual **VM43** or electric **VE43**

6 = 3/3 manual locking valve **VM33L** with pilot operated check

8 = 4/3 manual locking valve **VM43L** with pilot operated check

10⁶⁾ = 3 way/3 position manual **Venturi** valve **VM33VAC**

11⁶⁾ = 3 way/3 position electric **Venturi** valve **VE33VAC**

5 Reservoir Capacity

04 = 4,6 litres (not available on ZE5, ZE6)

08 = 6,8 litres (not available on ZE5, ZE6)

10 = 9,8 litres

20 = 19,8 litres

40 = 39,0 litres

6 Valve Operation

D = Dump solenoid valve with pendant and LCD

L = Manual valve with LCD Electric (without pendant)

M = Manual valve, without pendant or LCD

N = No valve, no electric box

S = Solenoid valve, with pendant and LCD

7 Motor Voltage

Single phase motor (not on ZE5, ZE6)

B¹⁾ = 115V, 1 ph, 50-60 Hz

E = 208-240V, 1 ph, 50-60 Hz with European SCHUKO Plug

I = 208-240V, 1 ph, 50-60 Hz with USA Nema 6-15 plug

Three phase motor³⁾

G = 208-240V, 3 ph, 50-60 Hz

J = 460-480V, 3 ph, 50-60 Hz

W = 380-415V, 3 ph, 50-60 Hz

▼ STEP 2: Factory Installed Accessories

Select factory installed accessories and add to the pump model number after the hyphen. The example above shows that a **Return Line Filter (F)** and **Heat Exchanger (H)** have been added to the pump.

8 Factory installed accessories include the following:

F = Return Line Filter

G = Pressure Gauge⁴⁾

H = Heat exchanger²⁾

K = Skid Bar

L = Level/Temperature switch²⁾

N = Lifting Eyes (no reservoir handles)⁷⁾

P = Pressure Switch²⁾

R = Roll Cage

S = Single stage pump unit⁵⁾

T = Pressure transducer²⁾⁴⁾

U = Foot switch²⁾

¹⁾ 115-volt pumps are supplied with 15-Amp plug for intermittent use. 20-Amp circuit recommended for frequent full pressure use.

²⁾ These accessories (H, L, P and T) require LCD electrical package. Level/Temperature switch (L) not available on 4,6 or 6,8 litres reservoir. Pressure switch option (P) only available on manual valves without locking valve. The LCD electrical package can accept either a pressure switch or pressure transducer, but not both.

³⁾ Pump with 3-ph motors without Electric Box shipped without cord, motor starter or overload protection.

⁴⁾ Pressure gauge (G) not available on pump models with pressure transducer. Pressure transducer provides digital pressure readout on LCD display.

⁵⁾ Not available on pumps with Venturi Valve Type 10 or 11.

⁶⁾ Not available on ZE3-Series pumps.

⁷⁾ Lifting eyes (N) not available on reservoir capacities 04 or 08.

▼ ZE-SERIES PUMP MODELS

No Valve, with coverplate, no electric box	
<p>Manual Valve without Electric Box or LCD</p> <ul style="list-style-type: none"> • Ideal choice for most applications • Manual valve control, for both single-acting or double-acting applications • Venturi Valve Technology (VM33VAC) for faster retract of single-acting cylinders • Manual motor control • On/off switch on 1-phase electric motor. 	
Solenoid Dump Valve, Electric Box and LCD	
<ul style="list-style-type: none"> • Ideal for punching, crimping and cutting • For use when load holding is not required • Push-button control pendant with 3 m. cord controls the valve and motor. 	
Solenoid 3-position Valve with Electric Box	
<ul style="list-style-type: none"> • Ideal for production and lifting applications • All valves are 3-position for Advance-Hold-Retract • Venturi Valve Technology (VE33VAC) for faster retract of single-acting cylinders • Push-button control pendant with 3 m. cord controls the valve and motor. 	

ZE-Series, Pump Ordering Matrix

S/A or D/A ¹⁾	Hold 	Valve Type ²⁾	Reservoir Capacity (litres)	ZE3-Series (0,75 kW) Output Flow Rate at 700 bar: 0,55 l/min		ZE4-Series (1,12 kW) Output Flow Rate at 700 bar: 0,82 l/min		ZE5-Series (2,24 kW) Output Flow Rate at 700 bar: 1,64 l/min		ZE6-Series (5,60 kW) Output Flow Rate at 700 bar: 2,73 l/min	
				Model Number ³⁾ E = 230 V, 1 ph	(kg)	Model Number ³⁾ E = 230 V, 1 ph	(kg)	Model Number ³⁾ W = 400 V, 3 ph	(kg)	Model Number ³⁾ W = 400 V, 3 ph	(kg)
		–	6,8	ZE3008NE (B, I, J, G, W)	45	ZE4008NE (B, I, J, G, W)	43	–	–	–	–
		–	9,8	ZE3010NE (B, I, J, G, W)	45	ZE4010NE (B, I, J, G, W)	49	ZE5010NW (J, G)	54	ZE6010NW (J, G)	72
		–	19,8	ZE3020NE (B, I, J, G, W)	57	ZE4020NE (B, I, J, G, W)	61	ZE5020NW (J, G)	66	ZE6020NW (J, G)	84
		–	39,0	ZE3040NE (B, I, J, G, W)	80	ZE4040NE (B, I, J, G, W)	84	ZE5040NW (J, G)	89	ZE6040NW (J, G)	107
S/A	–	VM22	19,8	–	–	ZE4720ME (B, W)	65	–	–	–	–
S/A	–	VM32	4,6	ZE3204ME (B)	39	–	–	–	–	–	–
S/A	–	VM32	6,8	ZE3208ME (B, I, J, G, W)	41	ZE4208ME (B, I, J, G, W)	45	–	–	–	–
S/A	–	VM32	9,8	ZE3210ME (B, I, J, G, W)	47	ZE4210ME (B, I, J, G, W)	51	ZE5210MW (J, G)	56	ZE6210MW (J, G)	74
S/A	–	VM32	19,8	ZE3220ME (B, I, J, G, W)	59	ZE4220ME (B, I, J, G, W)	64	ZE5220MW (J, G)	68	ZE6220MW (J, G)	86
S/A	●	VM33	4,6	ZE3304ME (B)	39	–	–	–	–	–	–
S/A	●	VM33	6,8	ZE3308ME (B, I, J, G, W)	42	ZE4308ME (B, I, J, G, W)	46	–	–	–	–
S/A	●	VM33	9,8	ZE3310ME (B, I, J, G, W)	48	ZE4310ME (B, I, J, G, W)	52	ZE5310MW (J, G)	57	ZE6310MW (J, G)	75
S/A	●	VM33	19,8	ZE3320ME (B, I, J, G, W)	60	ZE4320ME (B, I, J, G, W)	64	ZE5320MW (J, G)	69	ZE6320MW (J, G)	87
S/A	●	VM33	39,0	ZE3340ME (B, I, J, G, W)	83	ZE4340ME (B, I, J, G, W)	87	ZE5340MW (J, G)	92	ZE6340MW (J, G)	110
S/A	●	VM33VAC	6,8	–	–	ZE41008ME (B, I, J, G, W)	46	–	–	–	–
S/A	●	VM33VAC	19,8	–	–	ZE41020ME (B, I, J, G, W)	64	ZE51020MW (J, G)	69	ZE61020MW (J, G)	87
S/A	●	VM33VAC	39,0	–	–	–	–	ZE51040MW (J, G)	92	ZE61040MW (J, G)	110
S/A	●	VM33L	6,8	ZE3608ME (B, I, J, G, W)	42	–	–	–	–	–	–
S/A	●	VM33L	19,8	ZE3620ME (B, I, J, G, W)	62	ZE4620ME (B, I, J, G, W)	66	–	–	–	–
S/A	●	VM33L	39,0	ZE3640ME (B, I, J, G, W)	85	ZE4640ME (B, I, J, G, W)	89	–	–	–	–
D/A	●	VM43	4,6	ZE3404ME (B)	39	–	–	–	–	–	–
D/A	●	VM43	6,8	ZE3408ME (B, I, J, G, W)	42	ZE4408ME (B, I, J, G, W)	46	–	–	–	–
D/A	●	VM43	9,8	ZE3410ME (B, I, J, G, W)	48	ZE4410ME (B, I, J, G, W)	52	ZE5410MW (J, G)	57	ZE6410MW (J, G)	74
D/A	●	VM43	19,8	ZE3420ME (B, I, J, G, W)	60	ZE4420ME (B, I, J, G, W)	64	ZE5420MW (J, G)	69	ZE6420MW (J, G)	87
D/A	●	VM43	39,0	ZE3440ME (B, I, J, G, W)	83	ZE4440ME (B, I, J, G, W)	87	ZE5440MW (J, G)	92	ZE6440MW (J, G)	110
D/A	●	VM43L	6,8	ZE3808ME (B, I, J, G, W)	44	–	–	–	–	–	–
D/A	●	VM43L	19,8	ZE3820ME (B, I, J, G, W)	62	ZE4820ME (B, I, J, G, W)	66	ZE5820MW (J, G)	71	ZE6820MW (J, G)	–
D/A	●	VM43L	39,0	ZE3840ME (B, I, J, G, W)	85	ZE4840ME (B, I, J, G, W)	89	ZE5840MW (J, G)	94	ZE6840MW (J, G)	112
S/A	–	VE32D	4,6	ZE3104DE (B, I, J, G, W)	43	–	–	–	–	–	–
S/A	–	VE32D	6,8	ZE3108DE (B, I, J, G, W)	45	ZE4108DE (B, I, J, G, W)	49	–	–	–	–
S/A	–	VE32D	9,8	ZE3110DE (B, I, J, G, W)	52	ZE4110DE (B, I, J, G, W)	55	ZE5110DW (J, G)	62	ZE6110DW (J, G)	79
S/A	–	VE32D	19,8	ZE3120DE (B, I, J, G, W)	64	ZE4120DE (B, I, J, G, W)	68	ZE5120DW (J, G)	74	ZE6120DW (J, G)	92
S/A	–	VE32D	39,0	–	–	ZE4140DE (B, I, J, G, W)	91	ZE5140DW (J, G)	97	ZE6140DW (J, G)	114
S/A	●	VE33	4,6	ZE3304SE (B, I, J, G, W)	48	–	–	–	–	–	–
S/A	●	VE33	6,8	ZE3308SE (B, I, J, G, W)	51	ZE4308SE (B, I, J, G, W)	55	–	–	–	–
S/A	●	VE33	9,8	ZE3310SE (B, I, J, G, W)	57	ZE4310SE (B, I, J, G, W)	61	ZE5310SW (J, G)	67	ZE6310SW (J, G)	84
S/A	●	VE33	19,8	ZE3320SE (B, I, J, G, W)	69	ZE4320SE (B, I, J, G, W)	73	ZE5320SW (J, G)	79	ZE6320SW (J, G)	97
S/A	●	VE33	39,0	ZE3340SE (B, I, J, G, W)	92	ZE4340SE (B, I, J, G, W)	96	ZE5340SW (J, G)	102	ZE6340SW (J, G)	120
S/A	●	VE33VAC	6,8	–	–	ZE41108SE (B, I, J, G, W)	52	–	–	–	–
S/A	●	VE33VAC	19,8	–	–	ZE41120SE (B, I, J, G, W)	70	ZE51120SW (J, G)	76	ZE61120SW (J, G)	94
S/A	●	VE33VAC	39,0	–	–	–	–	ZE51140SW (J, G)	99	ZE61140SW (J, G)	117
D/A	●	VE43	4,6	ZE3404SE (B, I, J, G, W)	48	–	–	–	–	–	–
D/A	●	VE43	6,8	ZE3408SE (B, I, J, G, W)	51	ZE4408SE (B, I, J, G, W)	55	–	–	–	–
D/A	●	VE43	9,8	ZE3410SE (B, I, J, G, W)	57	ZE4410SE (B, I, J, G, W)	61	ZE5410SW (J, G)	67	ZE6410SW (J, G)	84
D/A	●	VE43	19,8	ZE3420SE (B, I, J, G, W)	69	ZE4420SE (B, I, J, G, W)	73	ZE5420SW (J, G)	79	ZE6420SW (J, G)	97
D/A	●	VE43	39,0	ZE3440SE (B, I, J, G, W)	92	ZE4440SE (B, I, J, G, W)	96	ZE5440SW (J, G)	102	ZE6440SW (J, G)	120

¹⁾ S/A or D/A = For use with Single-Acting or Double-Acting cylinders and tools. ²⁾ Additional details can be found in the Directional Control Valve section.

³⁾ "E" suffix model numbers shown are 230 VAC, 1-phase, 50/60 Hz. "W" suffix model numbers shown are 400 VAC, 3-phase, 50/60 Hz. Other voltages available as shown.

Replace "E" voltage suffix with selected voltage character. Model number order example: **ZE4108DB** is 115VAC, 1 phase, 50/60 Hz. See Ordering Guide page 106 for voltage descriptions.

NOTE: Voltage options K (440 VAC, 3-phase, 50/60 Hz) and R (575 VAC, 3-phase, 60 Hz) are available on select models. Contact your local representative for availability.

NOTE: Valve operation "L" available on pumps with manual valve. Substitute "M" for "L" valve operation. Example: **ZE3608LE**.



Electric Box ¹⁾

- Back-lit LCD
- Pump usage information, hour and cycle counts
- Low-voltage warning and recording
- Self-test and diagnostic capabilities
- Pressure read-out ²⁾
- Auto-mode pressure setting ²⁾
- Information can be displayed in six languages ³⁾

¹⁾ Included on pumps with solenoid valves.

²⁾ When used with optional pressure transducer.

³⁾ English, French, German, Italian, Spanish and Portuguese.

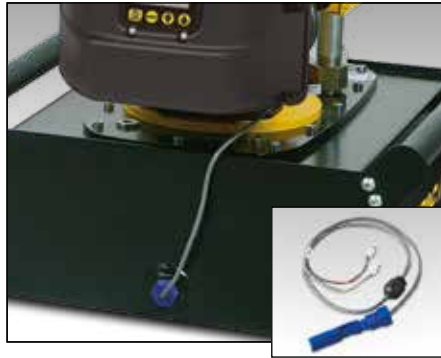

Level & Temperature Switch (L) ⁴⁾

- Shuts down pump before oil level reaches an unsafe level, avoiding damage due to cavitation
- Shuts down pump when unsafe oil temperature is reached
- Ideal if pump is used in remote area without visual access to oil level.

⁴⁾ 24 V, requires Electric Box. Available for 9,8; 19,8 and 39 litres reservoirs.



Return Line Filter (F)

- 25 micron nominal filter removes contaminants from return oil flow before allowing it back into tank
- Internal by-pass valve prevents damage if filter is dirty
- With maintenance indicator
- Replaceable filter element PF25.

Accessory Kit Modelnr.	Fixed Temperature Signal (°C)	Operating Temperature (°C)	Max. Pressure (bar)
ZLS-U4	80	5 - 110	10

Accessory Kit Modelnr.	Maximum Pressure (bar)	Maximum Oil Flow (l/min)	By-pass Setting (bar)
ZPF	13,8	45,4	1,7



Roll Cage (R)

- For easy portability and hoisting
- Protects pump and electric box
- Available for all reservoir sizes.



Skid Bar (K)

- Provides easy two-hand lift
- Provides greater pump stability on soft or uneven surfaces.



Foot Switch (U) ⁷⁾

- Hands-free remote control on solenoid dump and 3-position valves
- With 3 meters cord.

⁷⁾ 15 V, requires Electric Box.

Accessory Kit Nr.	Fits on reservoir size:	(kg)
ZRC-04	4,6 and 6,8 litres ⁵⁾	5,5
ZRC-04H	4,6 and 6,8 litres ⁶⁾	6,5
ZRB-10	9,8 litres	6,0
ZRB-20	19,8 litres	6,0
ZRB-40	39 litres	6,0

⁵⁾ For pump without heat exchanger

⁶⁾ For pump with heat exchanger.

Accessory Kit Nr.	Fits on reservoir size:	(kg)
SBZ-4	4,6 and 6,8 litres ⁵⁾	2,2
SBZ-4L	4,6 and 6,8 litres ⁶⁾	3,2

⁵⁾ For pump without heat exchanger

⁶⁾ For pump with heat exchanger.

Accessory Kit Nr.	Can be used on ZE-Series pumps with
ZCF-2	Solenoid VE-Series valves



Pressure Transducer (T) ¹⁾

- Displays pressure on LCD in bar, MPa or psi
- More accurate than analog gauge
- Calibration can be fine-tuned for certification
- Easy-viewing variable rate display
- "Set pressure" feature turns off motor at user defined pressure.

¹⁾ 24 V, requires Electric Box.



Pressure Switch (P) ²⁾

- Controls pump, monitors system
- Adjustable pressure 35-700 bar
- Includes glycerine filled 1000 bar pressure gauge G2536L
- Accuracy $\pm 1,5\%$ of full scale.

²⁾ 24 V, requires Electric Box. Not available in combination with pressure transducer. Not available on LCD-electronics.

Accessory Kit Modelnr.	Adjustable Pressure Range (bar)	Switch-point repeatability	Dead-band (bar)
ZPT-U4	3,5 - 700	$\pm 0,5\%$	3,5

Accessory Kit Modelnr.	Switch-point repeatability	Deadband (bar)	Oil Ports (NPTF)
ZPS-E3	$\pm 2\%$	8 - 38	3/8"



Heat Exchanger (H) ³⁾

- Removes heat from by-pass oil to provide cooler operation
- Stabilizes oil viscosity, increasing oil life and reduces wear of pump and other hydraulic components.

³⁾ 24 VDC, requires electric box.



Pressure Gauge (G)

- Minimize risk of overloading to ensure long life of equipment
- $\varnothing 63$ mm face diameter, glycerin filled
- Dual scale in bar and psi.

Note: Pressure Gauge not available on pump models with pressure transducer. The pressure transducer provides digital pressure read-out on LCD-display.

Accessory Kit Nr.	Fits on reservoir size:	(kg)
ZHE-E04	4,6 and 6,8 litres	4,1
ZHE-E10	9,8; 19,8 and 39 litres	4,1

Accessory Kit Model Nr.	Description
G2536L	0 - 1000 bar, 0 - 15.000 psi

ZE Series



Reservoir Capacity:

4,6 - 39 litres

Flow at Rated Pressure:

0,55 - 2,73 l/min

Motor Size:

0,75 - 5,60 kW

Maximum Operating Pressure:

700 bar



ZPT-U4 Pressure Transducer

More durable against mechanical and hydraulic shock than analog gauges.

- Digital pressure read-out provides accuracy of 0,5% of full scale.
- Easy-viewing variable rate display automatically varies increments between 3, 14, 35 and 145 bar as rate of pressure change increases.
- "Set pressure" feature turns off motor at user defined pressure (or shifts valve to neutral on VE33 and VE43 valves).



ZHE-Series Heat Exchangers

Heat exchanger stabilizes oil temperature at 54 °C at 21 °C ambient temperature. Thermal transfer at

1,9 l/min and 21 °C ambient temperature: 900 Btu/hour [950 kJ].

Do not exceed max. oil flow of 26,5 l/min and max. pressure of 20,7 bar. Not suitable for water-glycol or high water based fluids.